

HPS-S-R

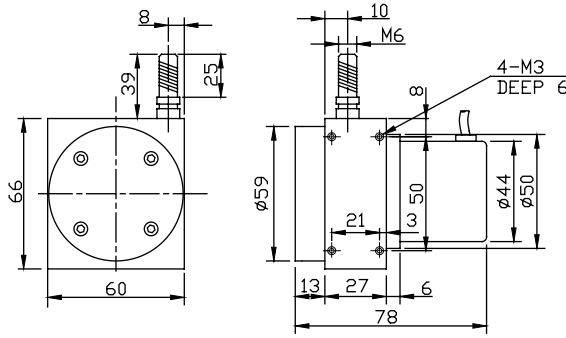

*DIMENSION (mm)

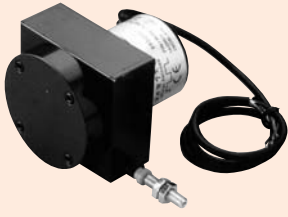
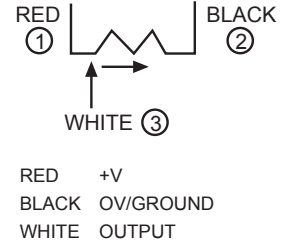

*ELECTRICAL CONNECTIONS

◀ LINEAR WIRE POTENTIOMETER ▶

- PRECISION ELECTRIC RESISTANCE SIGNAL OUTPUT
- SUITABLE FOR SHORT TO MEDIUM MEASUREMENT RANGE

ELECTRICAL SPEC.

Full Stroke (mm) 量測行程	250, 500, 1000
Output Signal Mode 輸出信號模式	Resistance (Potentiometer)
Linearity 線性度	±0.3%FS (standard class); ±0.1%FS (precision class)
Repeatability 重復性	±0.02%FS
Resolution 解析	Essentially infinite
Measurement Wire 線徑規格	Diameter 0.6 mm SUS304 with Nylon - coated, breaking load at 16 Kg
Sensor	Wire-wound and hybrid potentiometer
Starting Torque on Spring 拉力	< 600 g
Max. Measuring Wire Velocity (come and go) 最大往復速度	500 mm / sec.
Weight 重量	≤ 600 g

MECHANICAL SPEC.

Input Resistance 輸入電阻值	5K ohm ±10%FS (standard class), ±5%FS (precision class)
Power Rating (watts)	1 W at 70°C (for stroke 500 mm), 2 W at 70°C (for stroke 1000 mm)
Recommended Input Voltage 輸入電壓	30V(AC/DC) max., best voltage at 5 ~ 10Vac/dc

ENVIRONMENTAL SPEC.

Operating Temp. 操作溫度	0°C ~ +70°C
Storage Temp. 儲存溫度	-20°C ~ +80°C
Vibration 震動	10 Hz to 2000 Hz, 10 g
Protection 保護等級	IP 50

ORDERING INFORMATION

HPS-S	Measuring Range 量測行程	Signal Mode 信號模式	Life 壽命及線性度
	02: 200 mm 05: 500 mm 10: 1000 mm	R: resistance 5K ohm	Blank: 1 X 10 ⁶ cycles, linearity 0.25%FS *F: 5 X 10 ⁶ cycles, linearity 0.1%FS